

NEUE
HERBOLD
Granulators

LM



LM granulator range

Applications

The Neue Herbold LM range of granulators are specially designed for the size reduction of voluminous, medium and thin walled plastic waste materials. Typical applications are size reduction of films, hollow containers such as drums and bottles, thin walled pipes and profiles, car bumpers, injection moulded parts and sprues, thermoforming skeletal waste etc.

Design

The Neue Herbold LM range of granulators are designed with the true 'double cross cutting action' of oppositely inclined rotor and stator blades. This cutting geometry ensures a very precise cutting gap over the complete blade length thus giving lower power, noise and fines characteristics.

All blades, rotor and stator, are preadjusted simply outside of the machine in a supplied setting jig. The bearings are mounted outboard of the granulator hamber ensuring no cross ingress of grease, heat or fines.

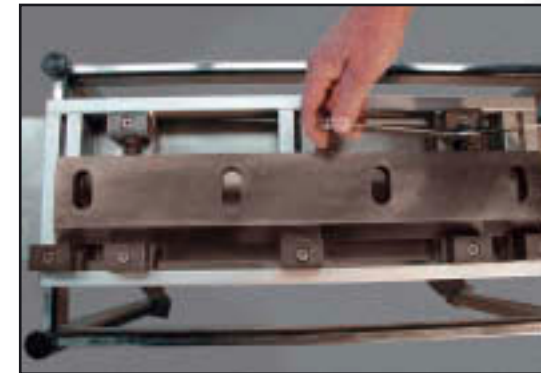

Rotor/Stator

knife adjustment

The rotor and stator knife adjustment is carried out outside of the granulator in a adjustment fixture prior to installation in the granulator.

Advantages

- Fully accessible machines for easy cleaning and easy routine maintenance
- Reduced downtime for blade changing due to preset blade feature
- Lower noise characteristics due to double cross cut action
- Compact layout for minimum space requirements
- Lower power, hence lower energy, characteristics

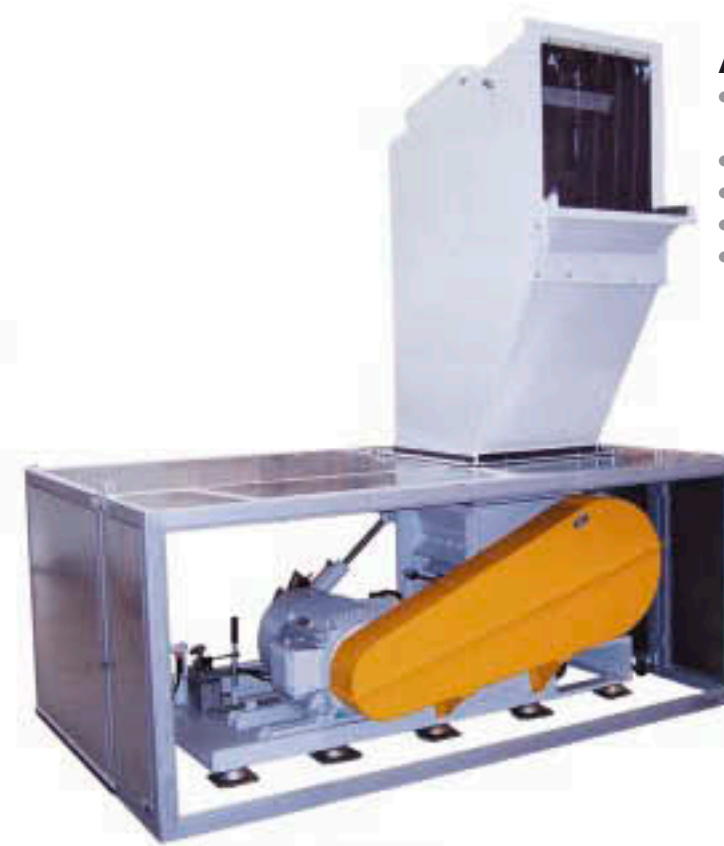

LM 300/500

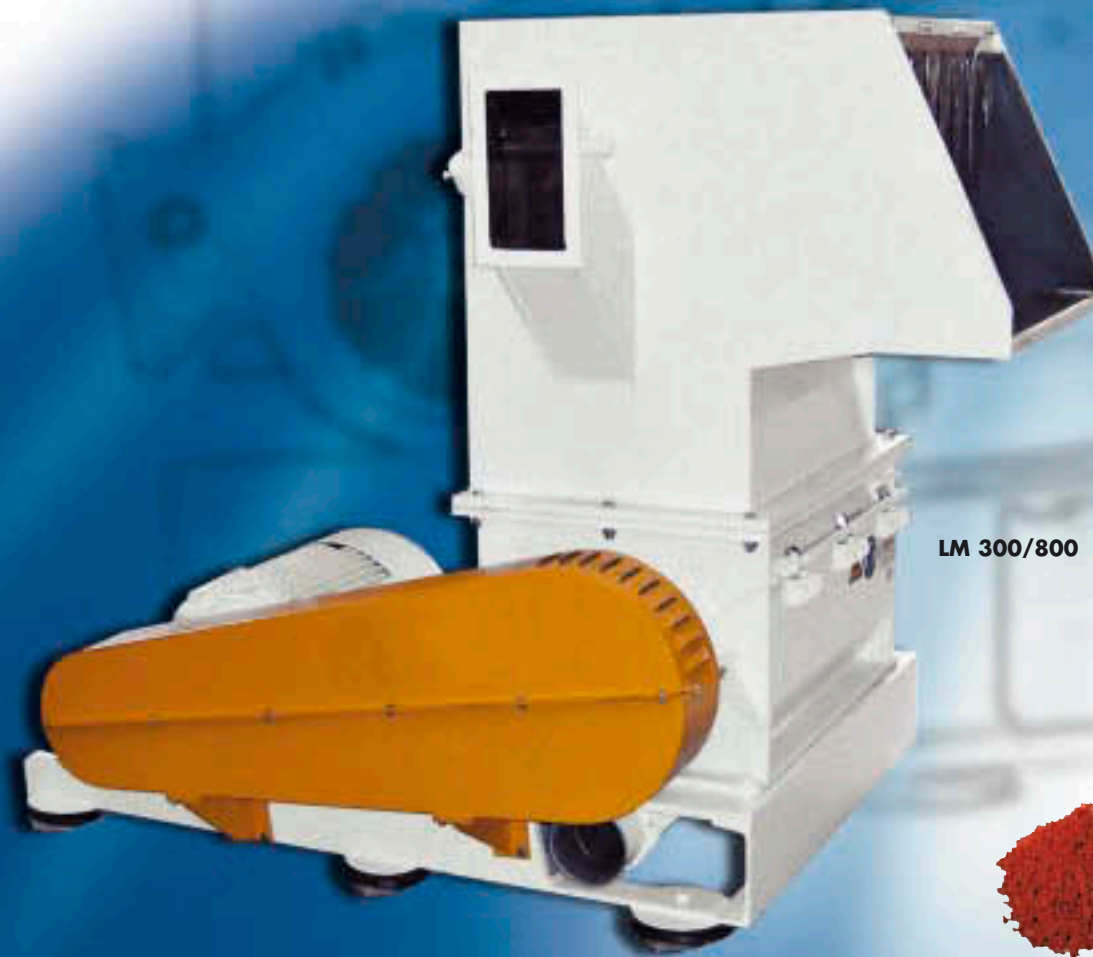

LM 300/800



LM 600/1000

Performance examples approx.

Type	Feed Opening	Rotor \varnothing	Drive	Weight	Throughput approx.
LM 300/300	500 x 290 mm	300 mm	11 - 22 kW	990 kg	100 - 220 kg/h
LM 300/500	500 x 490 mm	300 mm	15 - 22 kW	1500 kg	180 - 300 kg/h
LM 300/800	500 x 790 mm	300 mm	15 - 30 kW	1800 kg	300 - 500 kg/h
LM 300/1500	500 x 1420 mm	300 mm	15 - 37 kW	2800 kg	500 - 1000 kg/h
LM 450/600	600 x 580 mm	450 mm	22 - 55 kW	2590 kg	400 - 700 kg/h
LM 450/1000	600 x 970 mm	450 mm	30 - 75 kW	3800 kg	550 - 1100 kg/h
LM 450/1200	600 x 1150 mm	450 mm	45 - 75 kW	4750 kg	600 - 1200 kg/h
LM 600/1000	720 x 970 mm	600 mm	45 - 90 kW	4770 kg	700 - 1500 kg/h
LM 600/1200	720 x 1170 mm	600 mm	75 - 132 kW	6000 kg	1200 - 2500 kg/h

Dimensions approx. / mm

Type	A	B	C	D
LM 300/300	800	1400	290	1100
LM 300/500	800	1400	490	1300
LM 300/800	800	1700	790	1480
LM 300/1500	1000	2000	1420	2200
LM 450/600	1000	2200	580	1500
LM 450/1000	1200	2200	970	1900
LM 450/1200	1200	2200	1150	2100
LM 600/1000	1350	2300	970	2000
LM 600/1200	1200	2800	1170	2200

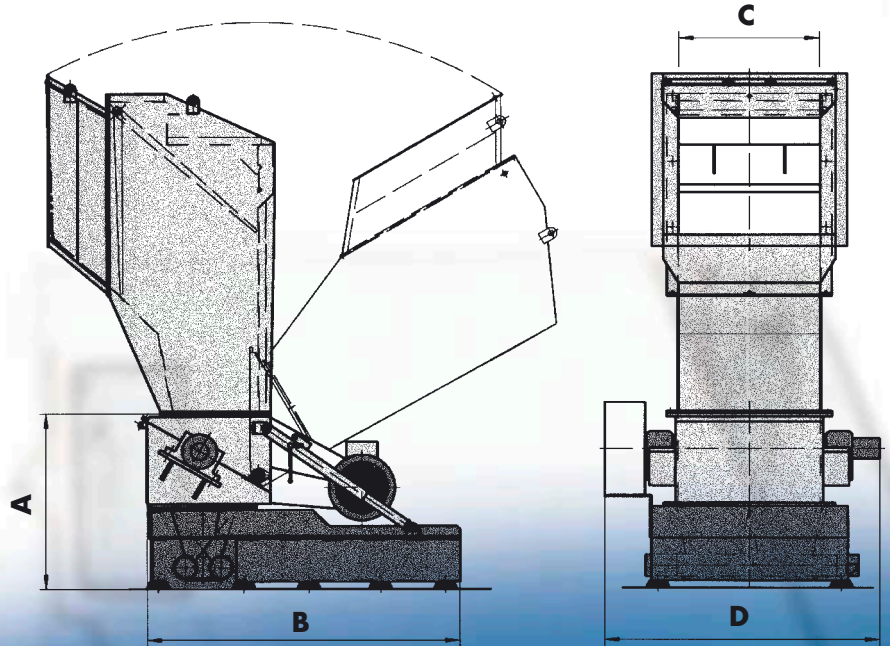

**NEUE
HERBOLD**

Maschinen- und Anlagenbau GmbH
 Wiesenstraße 44 · 74889 Sinsheim
 Telefon +49 (0) 7261 9248-0 · Telefax +49 (0) 7261 9248-99
 www.neue-herbold.com · info@neue-herbold.com